

EXPLODED DRAWING-MODEL NO. CEX1006ST.O

R0806A

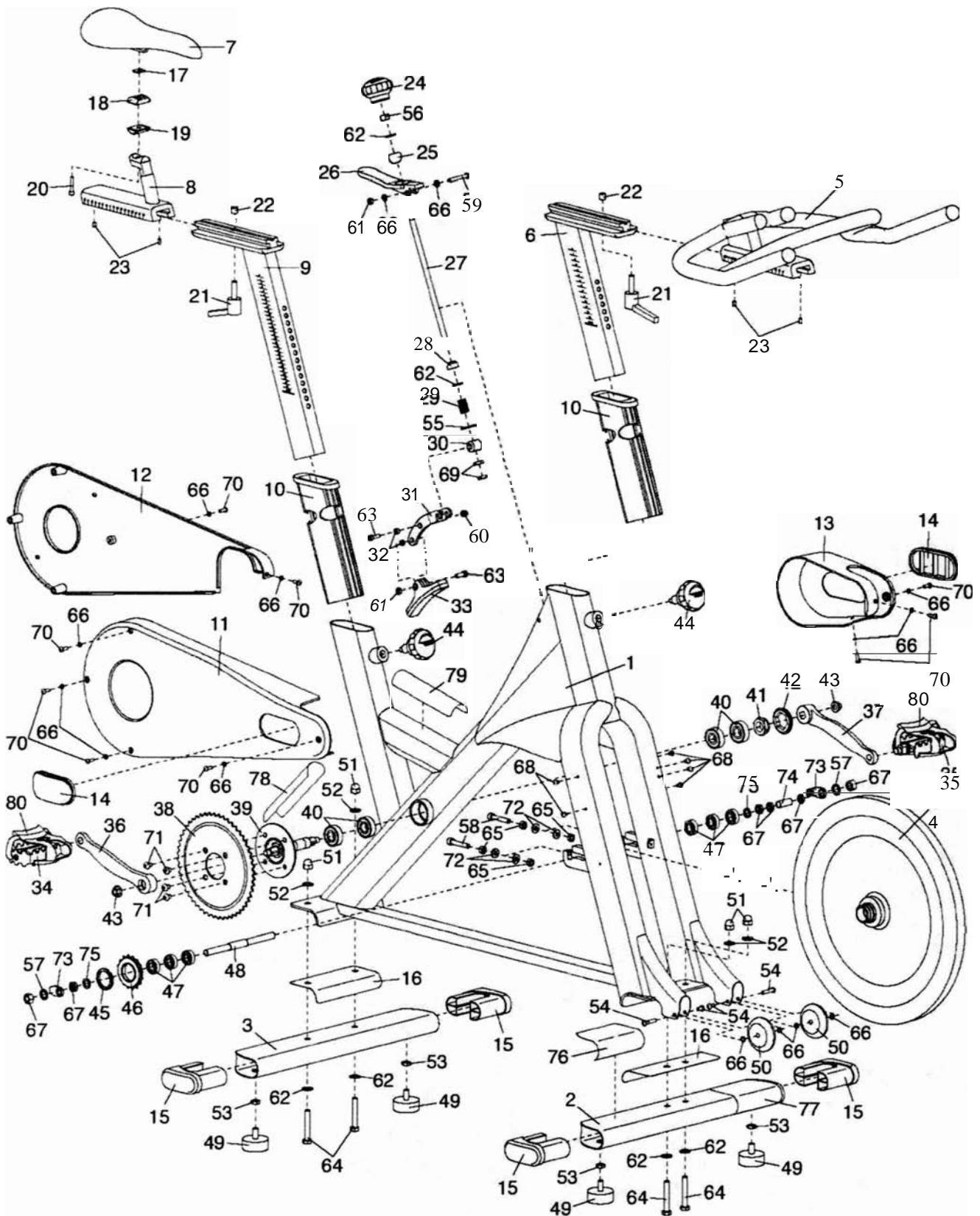

PART LIST-MODEL NO. CEX1006ST.O

R0806A

Key No.	Qty.	Description	Key No.	Qty.	Description
1	1	Frame	43	2	M10 Flange Nut
2	1	Front Stabilizer	44	2	Adjustment Knob
3	1	Rear Stabilizer	45	1	Lock Ring
4	1	Flywheel	46	1	Flywheel Sprocket
5	1	Handlebar	47	6	Flywheel Bearing
6	1	Handlebar Post	48	1	Flywheel Axle
7	1	Saddle	49	4	Leveling Foot
8	1	Saddle Carriage	50	2	Wheel
9	1	Saddle Post	51	4	M10 Acorn Nut
10	2	Frame Sleeve	52	4	Plastic Washer
11	1	Chain Guard	53	4	M10 Jamnut
12	1	Inner Chain Guard	54	2	M6 x 30mm Union Bolt
13	1	Hub Cover	55	1	M10 Fender Washer
14	2	Maintenance Cover	56	1	M10 Nylon Locknut
15	4	Stabilizer Endcap	57	2	M12 Lock Washer
16	2	Stabilizer Gasket	58	2	M8 x 45mm Adjustment Screw
17	1	Saddle Clamp Nut	59	1	M6 x 45mm Bolt
18	1	Upper Saddle Clamp	60	1	M6 Nylon Locknut
19	1	Lower Saddle Clamp	61	2	M6 Nut
20	1	M8 x 48mm Bolt	62	6	M10 Washer
21	2	Adjustment Handle	63	2	M6 x 20mm Bolt
22	2	Lock Bushing	64	4	M10 x 60mm Bolt
23	4	M6 x 8mm Set Screw	65	4	M8 Nut
24	1	Resistance Knob	66	15	M5 Washer
25	1	Socket Ball	67	6	M12 Axle Nut
26	1	Emergency Brake Handle	68	6	M5 x 15mm Screw
27	1	Brake Rod	69	2	M10 x 1mm Jamnut
28	1	Brake Bushing	70	9	M5 x 16mm Screw
29	1	Brake Spring	71	4	M10 x10mm Screw
30	1	Brake Pivot	72	4	M8 Washer
31	1	Brake Tension Arm	73	2	Capture Nut
32	2	Lever Bushing	74	1	Flywheel Spacer
33	1	Brake Pad	75	2	M12 Washer
34	1	Right Pedal	76	1	Right Stabilizer Shield
35	1	Left Pedal	77	1	Left Stabilizer Shield
36	1	Right Crank Arm	78	1	Lower Frame Shield
37	1	Left Crank Arm	79	1	Upper Frame Shield
38	1	Chain Ring	80	2	Pedal Toe Strap
39	1	Bottom Bracket Spindle	#	1	Roll Ring
40	4	Bottom Bracket Bearing	#	1	Chain
41	1	Bottom Bracket Locknut	#	1	Water Bottle Cage
42	1	Locknut Cover	#	1	User's Manual

Note: # indicates a non-illustrated part. Specifications are subject to change without notice. If replacement parts are needed, or if parts are missing, see HOW TO CONTACT CUSTOMER CARE on the back cover of this manual.